

D²Pak Package Outline

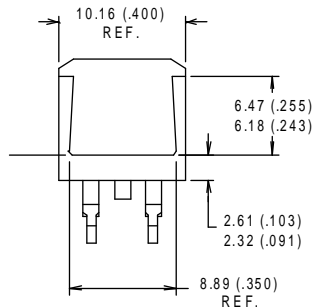

MINIMUM RECOMMENDED FOOTPRINT

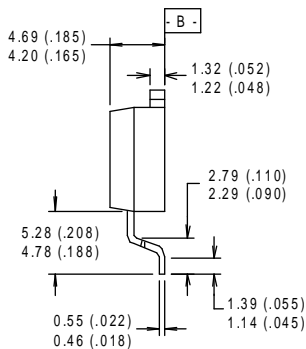
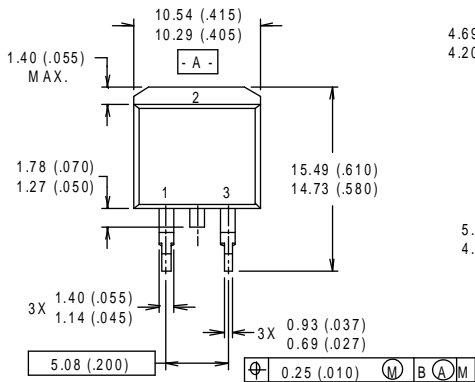
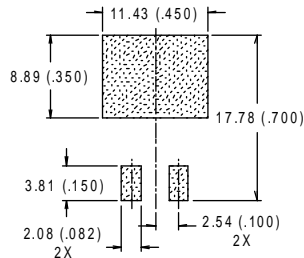

NOTES:

- 1 DIMENSIONS AFTER SOLDER DIP.
- 2 DIMENSIONING & TOLERANCING PER ANSI Y14.5M, 1982.
- 3 CONTROLLING DIMENSION : INCH.
- 4 HEATSINK & LEAD DIMENSIONS DO NOT INCLUDE BURRS.

LEAD ASSIGNMENTS

- 1 - GATE
- 2 - DRAIN
- 3 - SOURCE

Tape & Reel Information

D²Pak

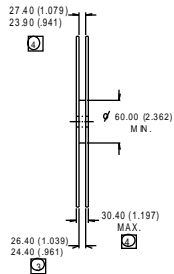
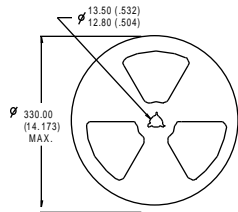
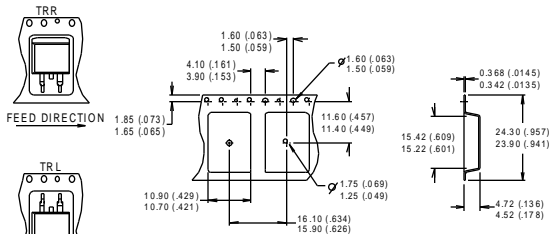

NOTES :

1. COMFORM ST0 EIA-418.
2. CONTROLLING DIMENSION : MILLIMETER.
- ① DIMENSION MEASURED @ HUB.
- ② INCLUDES FLANGE DISTORTION @ OUTER EDGE.